

Part Number: PT938-47161

Kit Contents

Item #	Quantity Req.	Description
1	2	Side Splitter (RH/LH)
2	2	Front Hanger Bracket (RH/LH)
3	2	Middle Hanger Bracket (RH/LH)
4	2	Rear Hanger Bracket (RH/LH)
5	1	Hardware Pack

Hardware Bag Contents

Item #	Quantity Req.	Description
1	20	8mm Ratchet Fastener
2	32	5/32" Rivet
3		

Additional Items Required For Installation

Item #	Quantity Req.	Description
1		
2		

Conflicts

None

Recommended Tools

Personal & Vehicle Protection	Notes
Safety Glasses	
Special Tools	Notes
Installation Tools	Notes
5/32" Drill Bit (#20)	
Drill	
Rivet Tool	
Drill Stop	20mm depth
Special Chemicals	Notes
VDC Approved Cleaner	

General Applicability

All standard Prius (not c or v) models
--

Recommended Sequence of Application

Item #	Accessory
1	
2	
3	

Vehicle Service Parts (may be required for reassembly)

Item #	Quantity Req.	Description
1		
2		
3		

Legend

 **STOP:** Damage to the vehicle may occur. Do not proceed until process has been complied with.

 **OPERATOR SAFETY:** Use caution to avoid risk of injury.

 **CAUTION:** A process that must be carefully observed in order to reduce the risk of damage to the accessory/vehicle and to ensure a quality installation.

 **TOOLS & EQUIPMENT:** Used in Figures calls out the specific tools and equipment recommended for this process.

 **REVISION MARK:** This mark highlights a change in installation with respect to previous issue.

 **SAFETY TORQUE:** This mark indicates that torque is related to safety.

Procedure

Care must be taken when installing this accessory to ensure damage does not occur to the vehicle. The installation of this accessory should follow approved guidelines to ensure a quality installation.

These guidelines can be found in the "Accessory Installation Practices" document.

This document covers such items as:

- Vehicle Protection (use of covers and blankets, cleaning chemicals, etc.).
- Safety (eye protection, rechecking torque procedure, etc.).
- Vehicle Disassembly/Reassembly (panel removal, part storage, etc.).
- Electrical Component Disassembly/Reassembly (battery disconnection, connector removal, etc.).

Please see your Toyota dealer for a copy of this document.

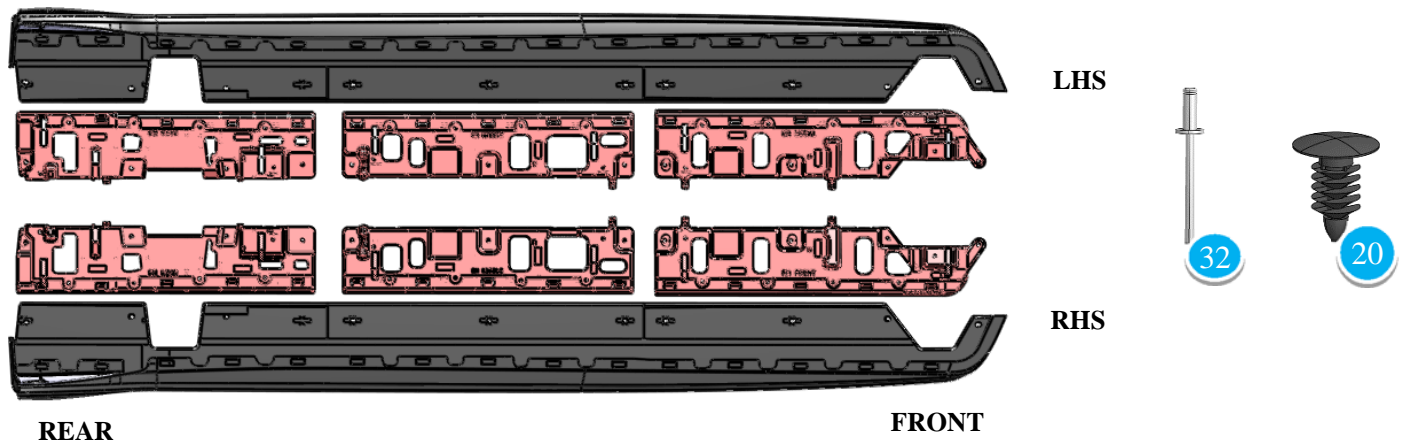

1. Inspect the Parts.

- (a) Remove each part from the box and inspect them for damage and quantity.

⚠ NOTE: Remove the protective film from the splitter to inspect it.

2. Prepare the Vehicle.

- (a) Lift the vehicle.

⊘ STOP (b) Ensure the vehicle is clean for the Side Splitter installation using VDC approved cleaner (Fig. 2-1).

⚠ NOTE: Keep the lifting apparatus clear of the installation area (Fig. 2-1).

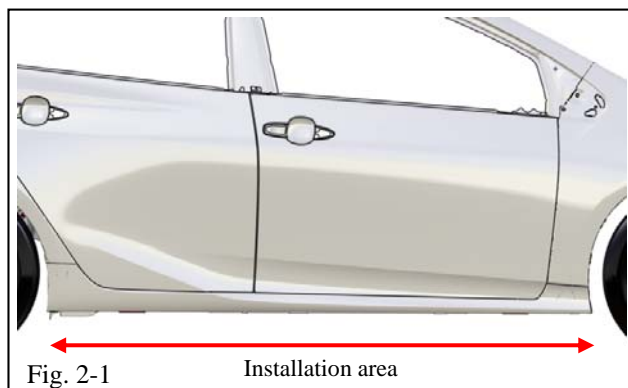

3. Install the Hanger Bracket.

STOP (a) Dry fit the rear hanger bracket (Fig. 3-1).

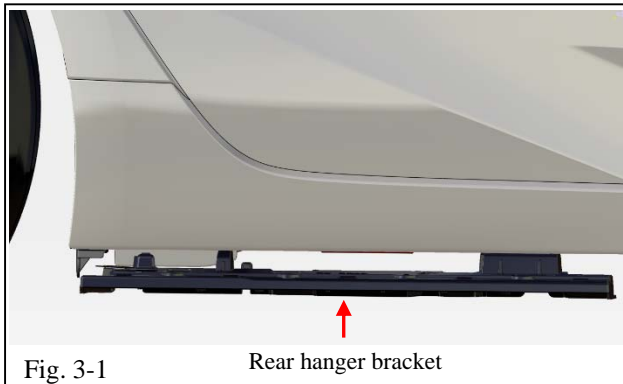

(b) Remove the tape liner tabs located on the rear hanger bracket (Fig. 3-2) and put the part in place.

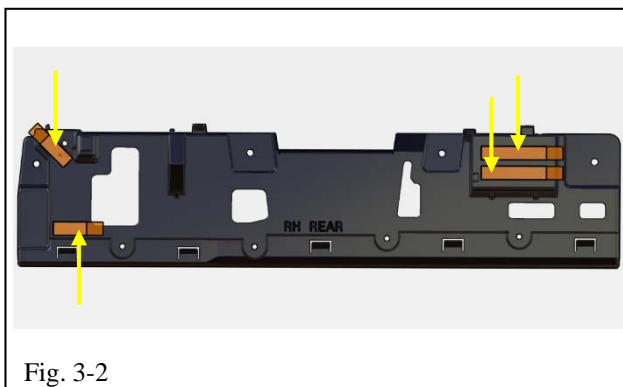

(c) Repeat Steps 3(a) & 3(b) for the middle bracket (Fig. 3-3).

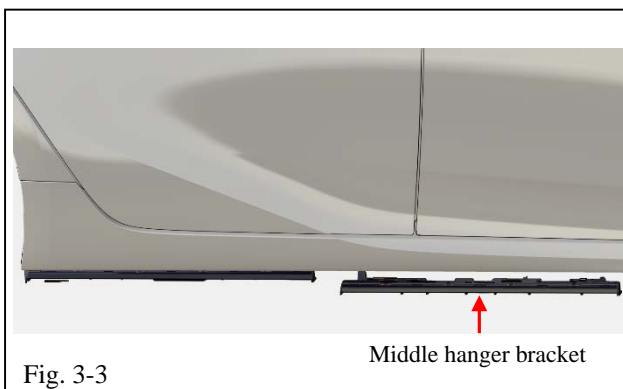

(d) Repeat Steps 3(a) & 3(b) for the front bracket (Fig. 3-4).



4. Drill the Hanger Bracket Holes.

+ (a) Wear eye protection when drilling through the rocker cladding.

(b) Set the drill depth to 20mm for the 5/32" drill (Fig. 4-1).

! **NOTE:** Only drill through the plastic rocker cladding. Do not drill into the vehicle sheet metal.

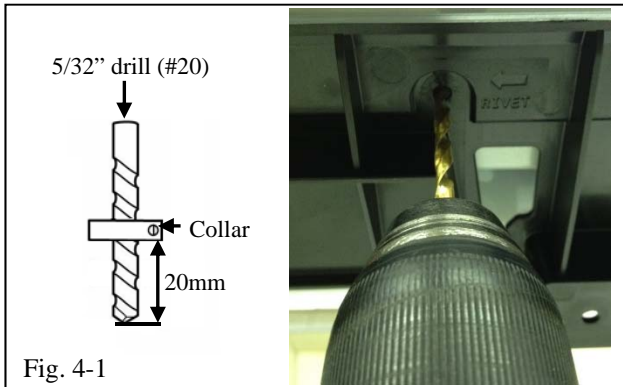

Fig. 4-1

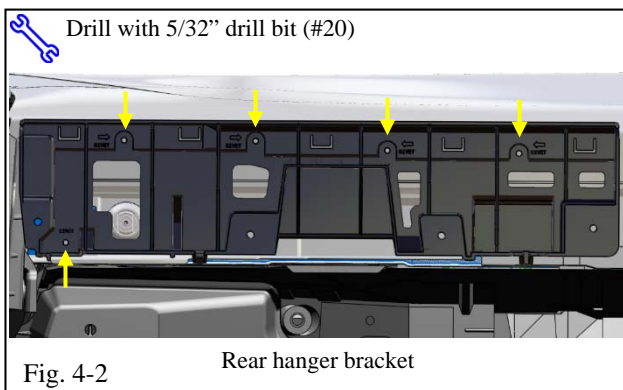

Fig. 4-2

Rear hanger bracket

! (c) Hold the rear hanger bracket and carefully use the drill with a 5/32" drill bit to drill the **5** marked locations on the hanger bracket (Fig. 4-2).

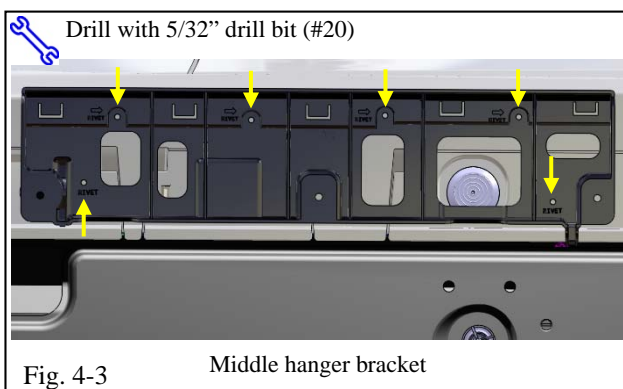
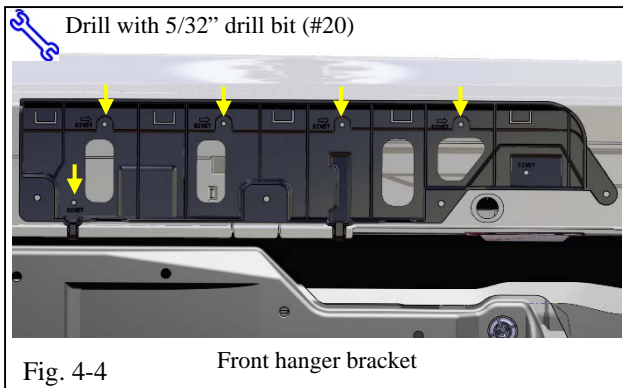

Fig. 4-3

Middle hanger bracket

! (d) Repeat Step 4(c) for the middle hanger bracket and carefully drill the **6** marked locations on the hanger bracket (Fig. 4-3).



- (e) Repeat Step 4(c) for the front hanger bracket and carefully drill the 5 marked locations on the hanger bracket (Fig. 4-4).

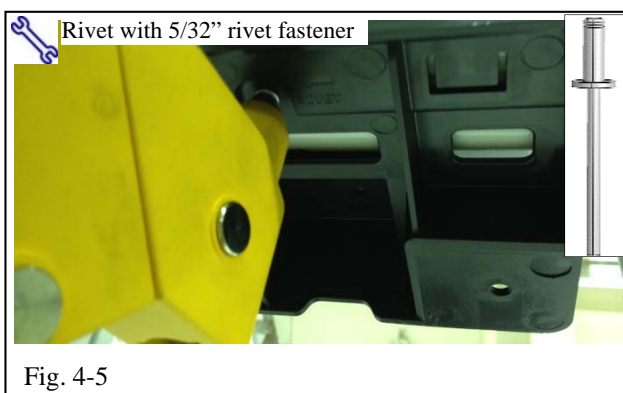

- (f) Use the rivet tool with a 5/32" rivet fastener to install a rivet on each of the drilled holes on the rear hanger bracket (Fig. 4-5).
- (g) Repeat Step 4(f) and install a rivet on each of drilled holes on the middle hanger bracket (Fig. 4-5).
- (h) Repeat Step 4(f) and install a rivet on each of the drilled holes on the front hanger bracket (Fig. 4-5).
- (i) Repeat Steps 4(a) through 4(h) on the other side of the vehicle.

5. Install the Side Splitter.

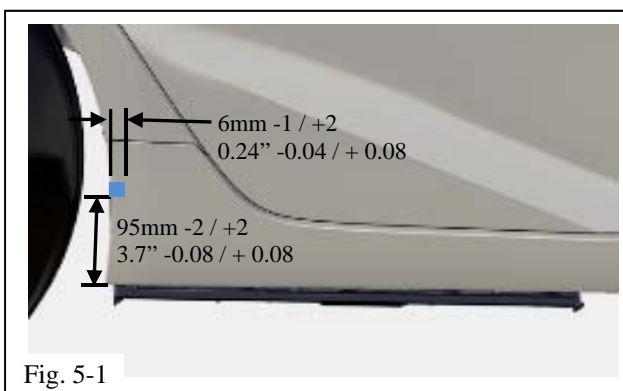

- (a) Apply locating tape to the rear as seen in Fig. 5-1. Mark the tape at the 6mm dimension shown.
- (b) Fold the tape tabs over the edges to be removed after the splitter is snapped into place.

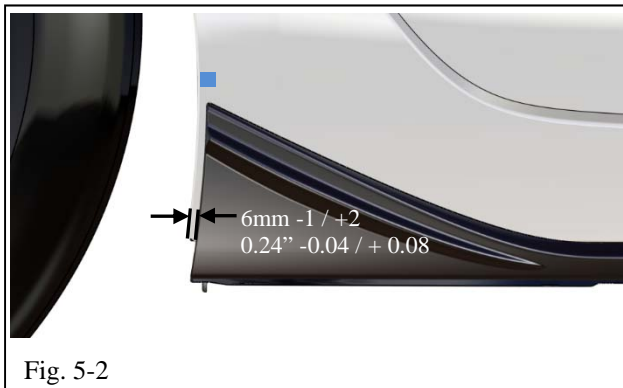

- (c) Align the rear edge of the side splitter to the **6mm (0.24")** locating mark (Fig. 5-2).
- (d) Push the side splitter inward onto the brackets until it snaps into place (audible click).

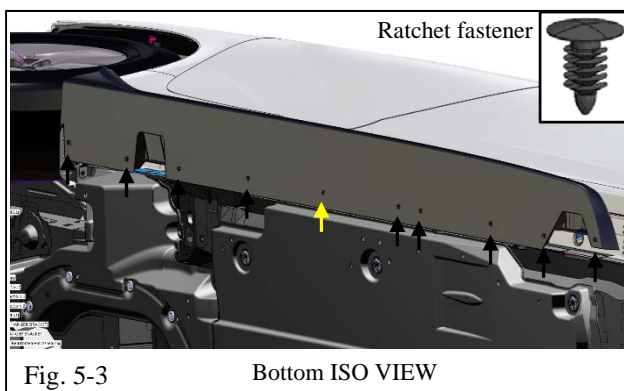

- (e) Starting with the hole located in the center of the splitter marked with the yellow arrow, insert a ratchet fastener in each of the locations shown (Fig. 5-3). Ensure each fastener is completely seated, 10 total.
- (f) Remove the tape liner from the rear of the splitter by pulling the exposed tape tabs.
- (g) Use a clean cloth to firmly press the splitter onto the vehicle.
- (h) Remove the marking tape and discard.
- (i) Repeat Steps 5(a) through 5(e) on the other side of the vehicle.

Checklist - these points **MUST** be checked to ensure a quality installation.

<u>Check:</u>	<u>Look For:</u>
<p><u>Accessory Function Checks</u></p> <ul style="list-style-type: none"><input type="checkbox"/> Ratchet fasteners are seated<input type="checkbox"/><input type="checkbox"/><input type="checkbox"/>	
<p><u>Vehicle Function Checks</u></p> <ul style="list-style-type: none"><input type="checkbox"/> None required<input type="checkbox"/><input type="checkbox"/>	
<p><u>Vehicle Appearance Check</u></p> <ul style="list-style-type: none"><input type="checkbox"/> After accessory installation and removal of protective cover(s), perform a visual inspection.	<p>Ensure no damage (including scuffs and scratches) was caused during the installation process. (For PPO installations, refer to TMS Accessory Quality Shipping Standard.)</p>